

INDUSTRIAL FACILITIES & EQUIPMENT EVALUATION FOR IMPACT & VIBRATION LOADINGS

Evaluation of structures for impact and vibration:

Failures due to vibration of machines and their supports may occur in industrial plants where heavy equipment employed in the process must be supported and where several machines are combined in close proximity. The dynamic response of the structure must be evaluated.

A dynamic analysis must consider two aspects of the structure's response to time dependent loading:

- Determining the magnitude of dynamic stress and amplitudes of vibration (displacements) and evaluate the serviceability of the structure in terms of fatigue stress, equipment operation, and human comfort.
- Ensure that the natural frequency of vibration of the system is sufficiently removed from the machine's exciting frequency to avoid unacceptable magnification of displacement and resulting stress in the machine and its supporting structure.

Serviceability requirements are a joint responsibility between client and designer:

Serviceability requirements and vibration levels that have not been clearly defined prior to commencement of detail design are cause for unnecessary grievances and misunderstandings between the client and the designer.

To avoid this problem, each facility of the plant which supports vibrating equipment should be established as a manned or unmanned station. Locations of sensitive equipment and/or instruments should be identified. Acceptable levels of vibration (displacements for a given frequency) must be established.

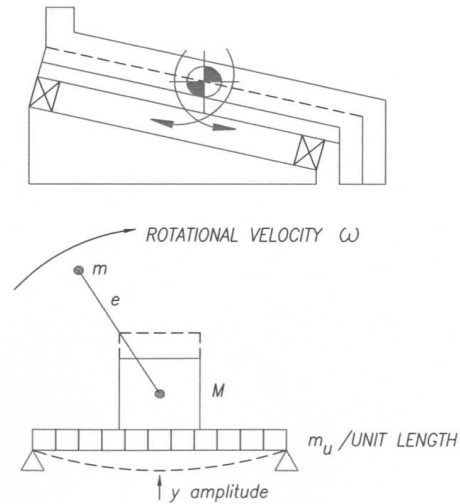

Figure 1 – ACTUAL SYSTEM

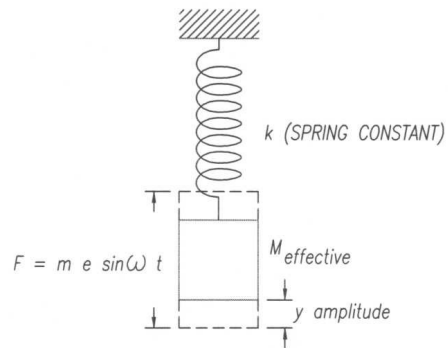

Figure 2 – EQUIVALENT SYSTEM

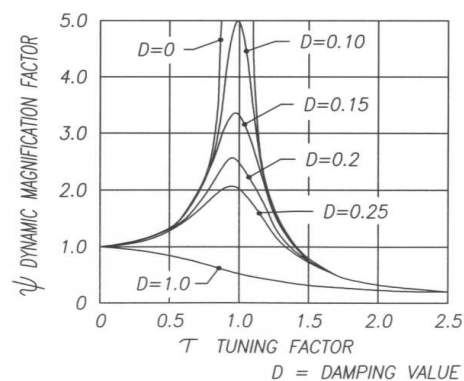

Figure 3 – DYNAMIC MAGNIFICATION

When human response to vibration is evaluated, the International Standards Organization ISO Standard 2631/1 should be considered. There are four physical factors of primary importance in determining the human response to vibration, namely, the intensity, the frequency, the direction, and the duration (exposure time) of the vibration. In the practical evaluation of any vibration, of which a physical description can be given in terms of these factors, three main human criteria can be distinguished:

- The preservation of working efficiency (fatigue-decreased proficiency boundary)
- The preservation of health or safety (exposure limit)
- The preservation of comfort (reduced comfort boundary)

Limits set for sensitive equipment should be obtained from the manufacturer.

Surveys, Testing and Evaluation

On site studies of existing machine/structure vibration are necessary once excessive vibration amplitude is suspected or fatigue of components is observed.

Evergreen Engineering can provide the diagnostic testing for machine/structure vibration and evaluate the findings with respect to vibration severity for machine/structure as well as human response.

Structural analysis is provided to determine the structures capability to safely resist the imposed loadings.

Maximum benefit from an evaluation program will result from the careful detail field investigation provided by Evergreen Engineering.

When corrective measures are required then Evergreen will provide detail custom design to meet acceptable serviceability requirements for structure, equipment, and personnel.